



## XR74 ECONOMY X-RAY

Value  
Quality  
Accuracy  
Reliability

## Upgrade from Metal Detection to X-Ray Technology

For over 50 years, Anritsu, a global technology leader, has been designing precision engineered inspection systems for the food, pharmaceutical and packaging industries. Around the globe, we provide a superior return on investment while ensuring your company is in compliance with the most stringent HACCP programs. As a single source supplier, no other company can provide better support, experience and technology to detect contaminants and product integrity checks within your product.

With over 10,000 global food X-Ray installations, Anritsu X-Ray systems are built with a commitment to quality and provide the best value in the industry. Anritsu provides an unmatched combination of performance, price and reliability.

**Discover what you've been missing.™**

Anritsu XR74e X-Ray solutions offer:

- **Exceptional value:** Anritsu's proven reliability at reasonable pricing.
- **Superior quality:** Precision engineered to the highest world standards.
- **Flexibility:** Standalone or integrated systems with reject and reject bin.
- **Easy cleaning and maintenance:** Designed to disassemble in minutes and diagnostic tools pinpoint errors.
- **Unbeatable reliability:** Rugged KD74 series x-ray platform.
- **Single source supplier:** Same office and technician supports all your inspection equipment.

# Anritsu provides a full range of X-Ray solutions to meet your requirements.

ANRITSU XR74e SOLUTIONS	XR74e-S	XR74e-M	XR74e-S Integrated	XR74e-M Integrated
<b>FEATURES</b>				
Low Power, 100W, X-Ray	✓	✓	✓	✓
Contaminant & count/missing detection	✓	✓	✓	✓
Virtual Weight (mass)	-	-	-	-
USB data collection and QuiCCA support	✓	✓	✓	✓
HACCP Ready - Event logs (NG, alarms, settings)	✓	✓	✓	✓
Reject Bin	-	-	✓	✓
Air Jet or Pusher Reject	Optional Kit	Optional Kit	✓	✓
Changeable (Flow and reject direction)	-	-	✓	✓
<b>SPECIFICATIONS</b>				
Typical Metal Detection	0.8-1.2mm	0.8-1.2mm	0.8-1.2mm	0.8-1.2mm
Typical Glass Detection	2.0-4.0mm	2.0-4.0mm	2.0-4.0mm	2.0-4.0mm
Belt Speed, standard	5 to 60m/min (3kg)	5 to 60m/min (5kg)	5 to 60m/min (3kg)	5 to 60m/min (5kg)
Belt Speed, optional	5 to 80m/min (2kg)	5 to 80m/min (3kg)	5 to 80m/min (2kg)	5 to 80m/min (3kg)
		5 to 40m/min (10kg)		5 to 40m/min (10kg)
Line Height	700 to 900mm	700 to 900mm	700 to 900mm	700 to 900mm
Reject Verify, Bin Full and Low Air Sensors	Optional	Optional	Optional	Optional
Air Conditioning (environment >35C or 95F)	Optional	Optional	Optional	Optional
Environmental Rating	IP40	IP40	IP40	IP40

**XR74e-S**

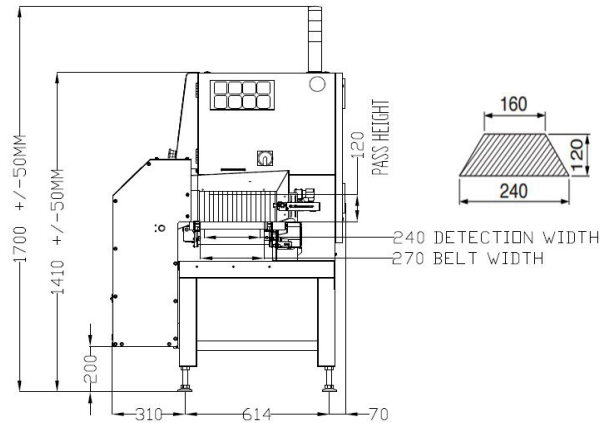
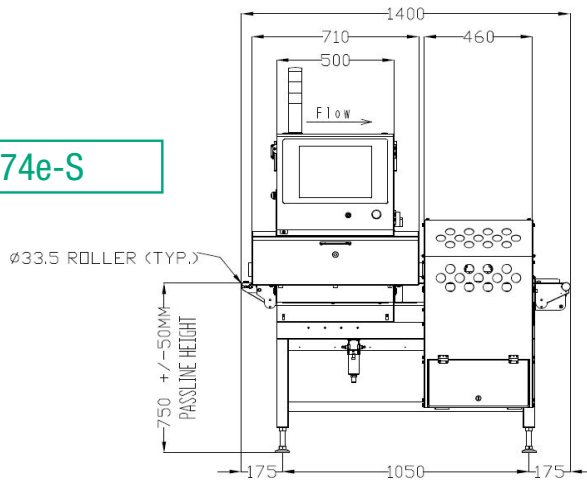

**XR74e-M**

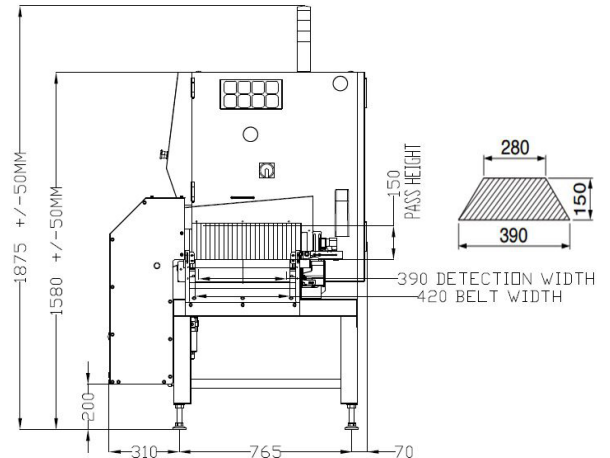
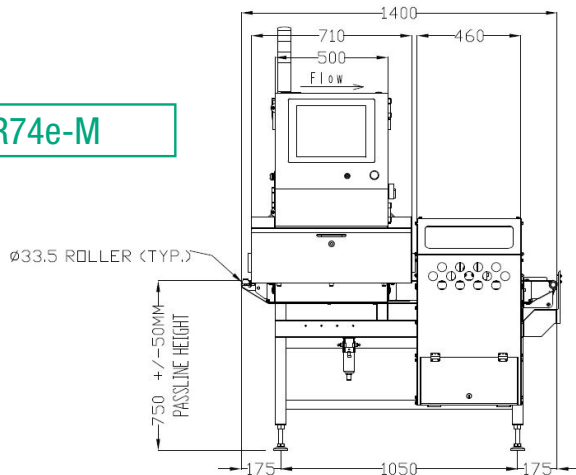

Subject to change, without notice

Anritsu Invisis, Inc.  
 1001 Cambridge Drive | Elk Grove Village, IL 60007-2453  
 +1 847-419-XRAY (9729) | [DetectionPerfection.com](http://DetectionPerfection.com)

**Anritsu**  
 envision:ensure